

New Products 2017



DIMENSIONAL METROLOGY NEW PRODUCTS

To ensure that you are always up-to-date,
Mahr continuously invests in new developments.

This is what **EXACTLY** means to us!

- 0 +



EXACTLY

Accurate length measurement for economical measurements and calibrations of test specimens.
This is what EXACTLY means to us!



The Precimar PLM 1000-E from Mahr offers a new standard in highly accurate length measurement: For the measurement of test specimens up to 1,000 mm, the measuring station offers more speed and measuring comfort. A new control, a new object table with increased accuracy in Z, motorized Y axis and a motorized tilting axis (TB) accelerate measurements and calibrations in measuring rooms and laboratories. Further information: Page 22

INDEX

MarCal Calipers	
MarCal Caliper 16 EWR / 16 ER Digital Caliper	2
MarCal 30 EWRi / 16 EWR Tiefenmessschieber	3
Micromar Micrometers	
Micromar 40 EWRi / 40 EWR / 40 ER Digital Micrometer	4
MarCator Indicators	
MarCator 1087 R / 1087 Ri Digital Indicator	8
Millimar Electrical and Pneumatic Length Measuring Instruments	
Millimar C 1700 PC Gaging Computer	10
Millimar Cockpit Software Measuring Software	12
Millimar N1702 / N1701 PS / N1701 USB / N1704 I/O Module for inductiv probes	14
Multimar Universal Measuring Instruments	
Multimar 844 S Setting Device	19
Precimar Precision Length Measurement	
Precimar 826 PC Gage block measuring instrument	20
Precimar Optimar 100 Dial indicator test device	21
Precimar PLM 1000-E Precision length measuring machine	22
MarSurf Surface Measuring Instruments	
MarSurf PS 10 C2 Mobile Roughness Measuring Instrument	23
MarGear Gear Measuring Instruments	
MarGear GMX 400 / GMX 400 ZLW Universal gear measuring center	25
MarGear MarWin Software solutions	27
MarShaft Shaft Measuring Instruments	
MarShaft Scope 250 plus	28
MarShaft Scope 600 plus 3D	29

MarCal 16 EWR / 16 ER. Digital Caliper

Functions 16 EWR:

- ON/OFF
- AUTO-ON / OFF
- RESET (set display to zero)
- PRESET (for entering a numerical value)
- Reversal of counting direction
- mm/inch
- LOCK function (key lock)



Functions 16 ER:

- ON/OFF
- AUTO-ON / OFF
- RESET (set display to zero)
- mm/inch
- LOCK function (key lock)

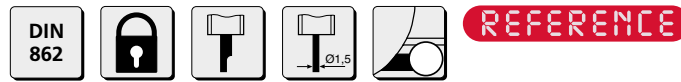

- High contrast analog display
- Locking screw above
- Lapped guide way
- Measuring blade for inside measurements
- Slide and beam made of hardened stainless steel
- Step measuring function
- Immediate measurements due to the Reference system
- Raised guide ways for the protection of the scale
- Excellent resistance against dust, coolants and lubricants
- Dirt wipers are integrated in the slide

Features 16 EWR:

- **Digit height:** 11 mm
- **Energy supply:** Battery, life span ca. 3 years
- **IP protection category:** IP 67
- **Scope of delivery:** Battery, Instruction manual, Case

Features 16 ER:

- **Digit height:** 11 mm
- **Energy supply:** Battery, life span ca. 3 years
- **Scope of delivery:** Battery, Instruction manual, Case

Technical Data

Order no.	Product type	Measuring range	Resolution	Error limit	Standard	Depth Rod	Friction wheel
		mm	mm/inch	mm			
4103304	16 EWR	0–200	0,01 / .0005"	0,03	DIN 862	rectangular	
4103305	16 EWR	0–200	0,01 / .0005"	0,03	DIN 862	rectangular	•
4103306	16 EWR	0–300	0,01 / .0005"	0,04	Factory standard		
4103307	16 EWR	0–300	0,01 / .0005"	0,04	Factory standard		•
4103205	16 ER	0–200	0,01 / .0005"	0,03	DIN 862	rectangular	
4103206	16 ER	0–200	0,01 / .0005"	0,03	DIN 862	rectangular	•
4103207	16 ER	0–300	0,01 / .0005"	0,04	Factory standard		
4103208	16 ER	0–300	0,01 / .0005"	0,04	Factory standard		•

Order no.	a	b	c	d	e
	mm	mm	mm	mm	mm
4103304	10	50	19	285	16
4103305	10	50	19	285	16
4103306	14	64	19	388	16
4103307	14	64	19	388	16
4103205	10	50	19	285	16
4103206	10	50	19	285	16
4103207	14	64	19	388	16
4103208	14	64	19	388	16

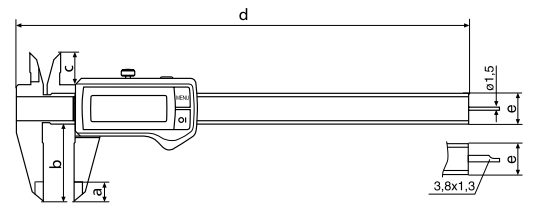

Accessories

Order no.	For measuring instrument	Product name	Product type
4102020	16 ER, 16 ER, 16 ER, 16 ER, 16 EWR, 16 EWR, 16 EWR, 16 EWR	Depth bridge (75 x 7 mm)	16 Em
4102520	16 ER, 16 ER, 16 ER, 16 ER, 16 EWR, 16 EWR, 16 EWR, 16 EWR	Battery 3 V, CR 2032	

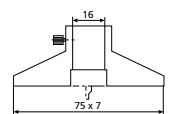

16 Em

MarCal 30 EWRi / 30 EWR. Digital Depth Gage

Functions 30 EWRi:

- ON/OFF
- AUTO-ON / OFF
- RESET (set display to zero)
- mm/inch
- PRESET (for entering a numerical value)
- LOCK function (key lock)
- HOLD (storage of measured values)
- Reversal of counting direction
- DATA (Data transmission)



REFERENCE



Functions 30 EWR:

- AUTO-ON / OFF
- DATA (Data transmission via connection cable)
- ON/OFF
- PRESET (for entering a numerical value)
- RESET (set display to zero)
- mm/inch
- LOCK function (key lock)



REFERENCE



- High contrast analog display
- Locking screw above
- Lapped guide way
- Measuring surfaces made of steel
- Slide and beam made of hardened stainless steel
- Immediate measurements due to the Reference system
- Raised guide ways for the protection of the scale
- Excellent resistance against dust, coolants and lubricants
- Dirt wipers are integrated in the slide
- **Software:** MarCom Professional free download: www.mahr.com/marcom (only for Mahr data cables and wireless systems with USB and RS232 interface)

Technical Data

Order no.	Product type	Measuring range	Resolution	Error limit	Standard
		mm	mm/inch	mm	
4126754	30 EWRi	0 – 200	0,01 / .0005"	0,03	Factory standard
4126699	30 EWR	0 – 200	0,01 / .0005"	0,03	Factory standard

Order no.	a	b
	mm	mm
4126754	284	100
4126699	284	100

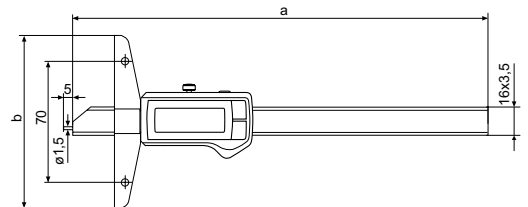

Features 30 EWRi:

- **Digit height:** 11 mm
- **Data interface:** Integrated wireless
- **Energy supply:** Battery life approx. 3 years (approx. 0.5 in wireless mode)
- **IP protection category:** IP 67
- **Scope of delivery:** Battery, Instruction manual, Case

Features 30 EWR:

- **Digit height:** 8,5mm
- **Data interface:** USB, Opto RS232C, Digimatic
- **IP protection category:** IP 67
- **Scope of delivery:** Battery, Instruction manual, Case

Accessories

Order no.	For measuring instrument	Product name	Product type
4102220	30 EWRi	Receiver incl. Software MarCom Std.	i-Stick
4102357	30 EWR	16 EXu Data Connection Cable USB (2 m) incl. Software MarCom Std.	16 EXu
4102410	30 EWR	Data Connection Cable RS232C (2 m)	16 EXr
4102520	30 EWR, 30 EWRi	Battery 3 V, CR 2032	
4102915	30 EWR	Digimatic data cable (2 m)	16 EWd
4125611	30 EWR, 30 EWRi	Anvil (4 mm)	30 ESa
4126510	30 EWR, 30 EWRi	Cross Beam Extension (300 mm)	30 EXm
4126511	30 EWR, 30 EWRi	Cross Beam Extension (200 mm)	30 EXm



i-Stick

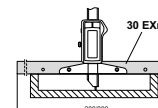

30 EXm

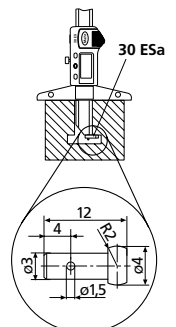

30 ESa

Micromar 40 EWRI. Digital Micrometer

Functions

- RESET (set display to zero)
 - ABS (display can be set to zero without losing reference to ORIGIN)
 - mm/inch
 - ORIGIN (for entering a numerical value)
 - LOCK function (key lock)
 - TOL (Tolerance and warning limits)
 - DATA (Data transmission)
 - HOLD (storage of measured values)
- High contrast analog display
 - Spindle is hardened throughout and ground, stainless
 - Spindle and anvil are carbide tipped
 - Rapid drive
 - Ratchet is integrated in the thimble
 - Lacquered steel frame, heat insulated
 - **Software:** MarCom Professional free download: www.mahr.com/marcom (only for Mahr data cables and wireless systems with USB and RS232 interface)
 - **Digit height:** 10 mm
 - **Data interface:** Integrated wireless
 - **IP protection category:** IP 65
 - **Scope of delivery:** Instruction manual, Battery, Setting standard (from measuring range 25–50 mm), Case



REFERENCE

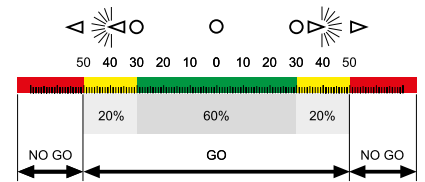

Technical Data

Order no.	Product type	Measuring range		Resolution	Error limit	Spindle thread pitch	Measuring force
		mm	mm/inch				
4157100	40 EWRI	0 – 25	0,001 / .00005"	2	2	0,5	5 – 10
4157101	40 EWRI	25 – 50	0,001 / .00005"	2	2	0,5	5 – 10
4157102	40 EWRI	50 – 75	0,001 / .00005"	3	3	0,5	5 – 10
4157103	40 EWRI	75 – 100	0,001 / .00005"	3	3	0,5	5 – 10

Order no.	a	b	c
	mm	mm	mm
4157100	24	9,5	32
4157101	36	11	57
4157102	45	13	82
4157103	57	13	107

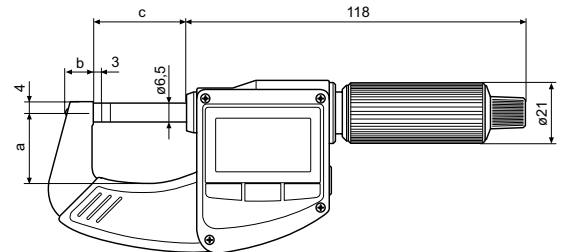

Accessories

Order no.	Product name	Product type
4102220	Receiver incl. Software MarCom Std.	i-Stick
4102520	Battery 3 V, CR 2032	
4158000	Stand, for holding outside micrometers	41 H



i-Stick



41 H

Micromar 40 EWRI. Digital micrometer set

Functions

- RESET (set display to zero)
- ABS (display can be set to zero without losing reference to ORIGIN)
- mm/inch
- ORIGIN (for entering a numerical value)
- LOCK function (key lock)
- TOL (Tolerance and warning limits)
- DATA (Data transmission)
- HOLD (storage of measured values)
- High contrast analog display
- Spindle is hardened throughout and ground, stainless
- Spindle and anvil are carbide tipped
- Rapid drive
- Ratchet is integrated in the thimble
- Lacquered steel frame, heat insulated
- **Software:** MarCom Professional free download:
www.mahr.com/marcom (only for Mahr data cables and wireless systems with USB and RS232 interface)
- **Digit height:** 10 mm
- **Data interface:** Integrated wireless
- **IP protection category:** IP 65
- **Scope of delivery:** Instruction manual, Battery, Setting values, Case



REFERENCE

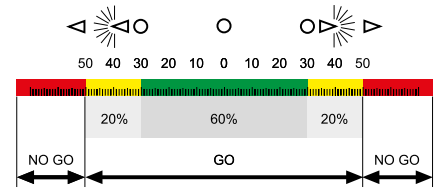

Technical Data

Order no.	Product type	Measuring range	Resolution	Spindle thread pitch	Measuring force	Number of Micrometers
4157115	40 EWRI	0 – 100	mm/inch 0,001 / .00005"	mm 0,5	N 5 – 10	4

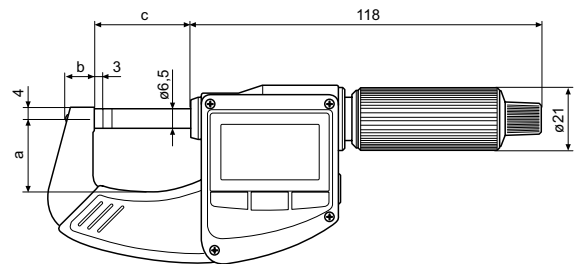

Accessories

Order no.	Product name	Product type
4102220	Receiver incl. Software MarCom Std.	i-Stick
4102520	Battery 3 V, CR 2032	
4158000	Stand, for holding outside micrometers	41 H



i-Stick



41 H

Micromar 40 EWR. Digital Micrometer

Functions

- RESET (set display to zero)
- ABS (display can be set to zero without losing reference to preset)
- mm/inch
- PRESET (for entering a numerical value)
- LOCK function (key lock)
- HOLD (storage of measured values)
- High contrast analog display
- Spindle is hardened throughout and ground, stainless
- Spindle and anvil are carbide tipped
- Rapid drive
- Ratchet is integrated in the thimble
- Lacquered steel frame, heat insulated
- **Digit height:** 10 mm
- **IP protection category:** IP 65
- **Scope of delivery:** Instruction manual, Battery, Setting standard (from measuring range 25–50 mm), Case



REFERENCE



Technical Data

Order no.	Product type	Measuring range	Resolution	Error limit	Spindle thread pitch	Measuring force	Standard
		mm	mm/inch	µm	mm	N	
4157011	40 EWR	0 – 25	0,001 / .00005"	2	0,5	5 – 10	Factory standard
4157012	40 EWR	25 – 50	0,001 / .00005"	2	0,5	5 – 10	Factory standard
4157013	40 EWR	50 – 75	0,001 / .00005"	3	0,5	5 – 10	Factory standard
4157014	40 EWR	75 – 100	0,001 / .00005"	3	0,5	5 – 10	Factory standard

Order no.	a	b	c
	mm	mm	mm
4157011	24	9,5	32
4157012	36	11	57
4157013	45	13	82
4157014	57	13	107

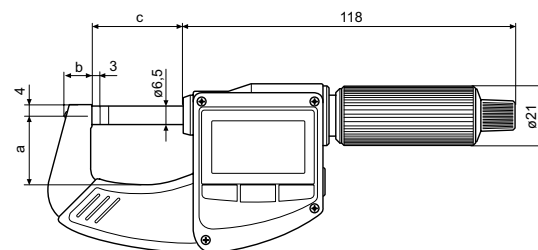

Micromar 40 ER. Digital Micrometer

Functions

- RESET (set display to zero)
- mm/inch
- HOLD (storage of measured values)
- LOCK function (key lock)
- High contrast analog display
- Spindle is hardened throughout and ground, stainless
- Spindle and anvil are carbide tipped
- Rapid drive
- Ratchet is integrated in the thimble
- Lacquered steel frame, heat insulated
- **Digit height:** 10 mm
- **IP protection category:** IP 40
- **Scope of delivery:** Instruction manual, Battery, Case



REFERENCE



Technical Data

Order no.	Product type	Measuring range	Resolution	Error limit	Spindle thread pitch	Measuring force	Standard
4157010	40 ER	0–25	mm/inch 0,001 / .00005"	μm 2	mm 0,5	N 5–10	Factory standard

Order no.	a	b	c
	mm	mm	mm
4157010	24	9,5	32

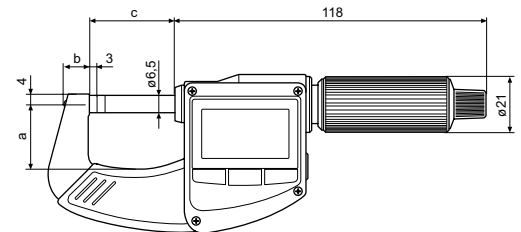

Accessories

Order no.	Product name	Product type
4102520	Battery 3 V, CR 2032	
4158000	Stand, for holding outside micrometers	41 H



41 H

MarCator 1087 R. Digital Indicator

Functions

- ON/OFF
 - RESET (set display to zero)
 - mm/inch
 - Reversal of counting direction
 - PRESET (for entering a numerical value)
 - TOL (enter tolerance limit values)
 - MAX/MIN memory for searching the reversal point
 - TIR (MAX-MIN) for testing flatness and concentricity
 - ABS (display can be set to zero without losing reference to preset)
 - DATA (Data transmission via connection cable)
 - Factor (adjustable)
 - LOCK (individual button lock)
- High contrast LCD
 - Operating and display unit (bezel) can be rotated through 280°
 - Immediate measurements due to the Reference system
 - Lift-off dust protection cap on end of measuring pin
 - Mounting shank and measuring spindle are both made of hardened stainless steel
 - **Software:** MarCom Professional free download:
www.mahr.com/marcom (only for Mahr data cables and wireless systems with USB and RS232C interface)
 - **Digit height:** 8,5 mm
 - **Data interface:** Opto RS232C, Digimatic, USB
 - **Energy supply:** Battery, life span ca. 3 years
 - **IP protection category:** IP 42
 - **Scope of delivery:** Instruction manual, Battery

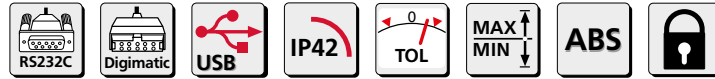

REFERENCE



Technical Data

Order no.	4337666	
Product type	1087 R	
Measuring span	mm	50
Resolution	mm	0,0005, 0,001, 0,002, 0,005, 0,01
Resolution	inch	.00002", .00005", .0001", .0002", .0005"
Graduation values	mm	0,001, 0,002, 0,005, 0,01, 0,02, 0,05
Range of analog display	mm	± 0,01, ± 0,02, ± 0,04, ± 0,1, ± 0,2
Error limit	mm	0,007
Error limit over 50 graduations	mm	0,002
Repeatability	mm	0,001
Measuring force	N	1,25 - 2,7
Standard	Factory standard	
Lifting protection cap	•	

Order no.	a	b	c	Mounting shaft
	mm	mm	mm	mm
4337666	267,3	40	52	8

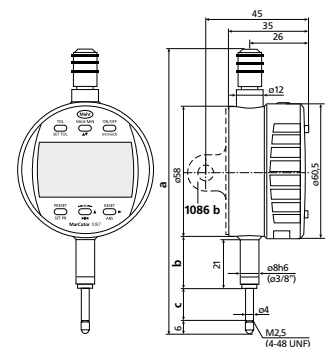

Accessories

Order no.	Product name	Product type
4884464	Battery 3 V, Type CR 2450	
4102357	16 EXu Data Connection Cable USB (2 m) incl. Software MarCom Std.	16 EXu
4102915	Digimatic data cable (2 m)	16 EWd
4102410	Data Connection Cable RS232C (2 m)	16 EXr
4375004	Protective cap for 1075 R / 1086 R / 1087 R	1086 s
4337421	Lug back	1086 b
4336230	Pneumatic lifting (50 + 100 mm)	1082 p
4310103	Adapter bush (.375" / 8 mm)	940

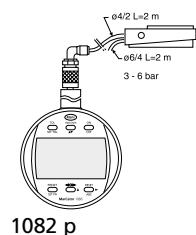

1082 p

MarCator 1087 Ri. Digital Indicator

Functions

- 0 (set the analog display to zero)
- ABS (display can be set to zero without losing reference to preset)
- AUTO-ON / OFF
- DATA (Data transmission via connection cable)
- Factor (adjustable)
- LOCK (individual button lock)
- MAX/MIN memory for searching the reversal point
- ON/OFF
- PRESET (for entering a numerical value)
- RANGE (switch the measuring range and resolution)
- RESET (set display to zero)
- TIR (MAX-MIN) for testing flatness and concentricity
- TOL (enter tolerance limit values)
- Reversal of counting direction
- mm/inch
- **Software:** MarCom Professional free download: www.mahr.com/marcom (only for Mahr data cables and wireless systems with USB and RS232C interface)
- **Digit height:** 8,5 mm
- **Data interface:** Digimatic, Opto RS232C, USB, Integrated wireless
- **Energy supply:** Battery operation
- **IP protection category:** IP 42
- **Scope of delivery:** Instruction manual, Battery



Technical Data

Order no.	4337667	
Product type	1087 Ri	
Measuring span	mm	50
Resolution	mm	0,0005, 0,001, 0,002, 0,005, 0,01
Resolution	inch	.00002", .00005", .0001", .0002", .0005"
Graduation values	mm	0,001, 0,002, 0,005, 0,01, 0,02, 0,05
Range of analog display	mm	± 0,01, ± 0,02, ± 0,04, ± 0,1, ± 0,2
Error limit	mm	0,007
Error limit over 50 graduations	mm	0,002
Repeatability	mm	0,001
Measuring force	N	1,25 – 2,7
Standard	Factory standard	
Lifting protection cap	•	

Order no.	a	b	c	Mounting shaft
	mm	mm	mm	mm
4337667	267,3	40	52	8

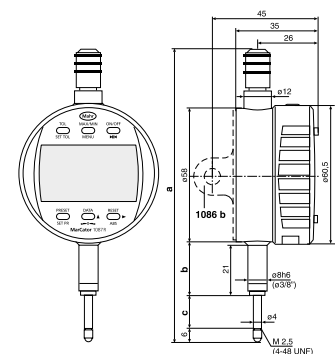

Accessories

Order no.	Product name	Product type
4884464	Battery 3 V, Type CR 2450	
4102357	16 EXu Data Connection Cable USB (2 m) incl. Software MarCom Std.	16 EXu
4102915	Digimatic data cable (2 m)	16 EWd
4102410	Data Connection Cable RS232C (2 m)	16 EXr
4375004	Protective cap for 1075 R / 1086 R / 1087 R	1086 s
4337421	Lug back	1086 b
4336230	Pneumatic lifting (50 + 100 mm)	1082 p
4310103	Adapter bush (.375" / 8 mm)	940

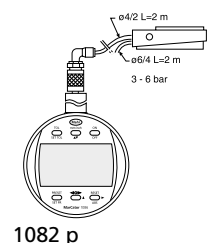

Millimar C 1700 PC. Gaging computer

- Interactive, touch-capable Software
- Simple and intuitive user interface
- Userfriendly setup of measuring tasks
- Simple operation via predefined formulas for most common features
- Management of measuring tasks
- Assignment of pictures or drawings per measuring task
- Static and dynamic measurements
- Supported by graphical control elements
- Live-indication of measuring values and features
- Digital and Analog displays for simultaneous indication of up to 128 features
- Connection of Mahr digital probes (USB) as well as Mahr instruments with USB-interface
- Connection of Mahr instruments with Integrated-Wireless
- Data export in MS-Excel or in qs-Stat-format (dfq, dfx or dfd-format)
- Password protected user levels (3 levels)
- Online-help (operating instruction) integrated in Cockpit software
- **Scope of delivery:** Millimar Cockpit Software incl. 10,1" Touch-PC, Preinstalled Windows 10 IoT Enterprise, Mahr license key, Installation disk, Recovery-Stick 16 GB, Operating instructions (online help), Mains adapter, VESA 100 standard stand



Application:

Comfortable measuring computer with an smart and universell applicable software for complex measuring tasks in the production area

Technical Data

Order no.		5312801
Product type		C 1700 PC
Display		Vertikale Balkenanzeige Horizontale Balkenanzeige Analoganzeige bzw. Rundskale Digitalanzeige Anzeigearten pro Merkmal frei kombinierbar
Range of digital display	mm	± 1000
Range of analog display	µm	± 10000, ± 5000, ± 2000, ± 1000, ± 500, ± 200, ± 100, ± 50, ± 20, ± 10
Resolution	µm	0,01
Length units		mm, µm, inch
Angle units		degrees, radians
Tolerance display		Obere u. untere Toleranzgrenze (pro Merkmal) Obere u. untere Warngrenze (pro Merkmal)
Compatibility		USB, Integrated wireless, Millimar N 1700
Measuring combination		Vordefinierte Formelvorlagen für Standardmerkmale Eingabe der Verknüpfungen über umfangreichen Formeleditor
Features		128
Feature types		Length, Angle, dimensionless
Dynamic functions		MAX, MIN, MAX-MIN, MAX+MIN
Classification		max. 20 Klassen
Measuring range	mm	Abhängig vom Messgerät
Number of connectable wireless receivers for i-stick		1
Number of connectable measuring instruments with integrated wireless		8
Number of connectable measuring instruments with USB interface		64
Data export		qs-Stat, Excel
Hardware interfaces		1x USB 3.0, 3x USB 2.0, 2x COM port Full-PIN (RS232/485; 5V/12V), 2x COM 2x COM port 3-PIN (RX, TX, GND; RS232/485 switchable), 2x 10/100/1000Mbit RJ45 Ports; 2x W-LAN connector, VGA, Display port
Energy supply:		100-240V ACDC active switching; 12V DC-Out
Power consumption		18
IP protection category:		IP 65 (Front Panel)
Languages:		German, English, Chinese, French, Russian, Czech
System requirements:		2 free USB 2.0 interfaces
Product weight	kg	2,00

Millimar C 1700 PC. Gaging computer

Accessories

Order no.	Product name	Product type
5331130	USB connecting module	N 1701 USB
5331120	Module for inductive probes	N 1702 M
5331133	Power supply module	N 1701 PS
5331134	I/O module	N 1704 I/O
4102220	Receiver incl. Software MarCom Std.	i-Stick
4102357	16 EXu Data Connection Cable USB (2 m) incl. Software MarCom Std.	16 EXu
4346023	2000 usb Data connection cable USB (2 m) incl. Software MarCom Std.	2000 usb
4305121	800 EWu Data Connection Cable USB (2 m) incl. Software MarCom Std.	800 EWu
4102331	Millimar - USB Adapter Cable RS232-USB (1 m) incl. Software MarCom Std.	Millimar - USB
4102330	Opto usb Adapter Cable RS232-USB (1 m) incl. Software MarCom Std.	Opto usb
4102333	817 usb Adapter Cable RS232-USB (1 m) incl. Software MarCom Std.	817 usb



N 1702 M



N 1701 PS



N 1701 USB



N 1704 I/O

Millimar Cockpit. Measuring software

- Interactive, touch-capable software
- Very simple and intuitive to use
- User-friendly creation of measuring tasks
- Access to predefined formula templates for maximum ease of use
- Management of measuring tasks (save and load function)
- Measuring task linked to images or drawings
- Static and dynamic recording of measuring values
- Supported by graphical operating elements
- Live visualization of measured values
- Simultaneous digital and analog displays of up to 128 features
- Connection of inductive probes and Mahr measuring instruments via USB interface
- Connection of Mahr measuring instruments via Integrated Wireless
- Data export in MS Excel or qs-Stat format (dfq or dfx/dfd format)
- Password-protected user levels (3 levels)
- Online help (operating instructions) can be accessed directly from the software
- **Scope of delivery:** Mahr license key, Installation disk, Operating instructions (online help)



Application:

Smart, universal software for complex measuring tasks in the manufacturing sector



Technical Data

Order no.	5312800		
Product type	Cockpit		
Display	Vertical bar graph Horizontal bar graph Analog display or round scale Digital display Any combination of display types can be chosen for each feature		
Range of digital display	mm	± 1000	
Range of analog display	µm	± 10000, ± 5000, ± 2000, ± 1000, ± 500, ± 200, ± 100, ± 50, ± 20, ± 10	
Resolution	µm	0,01	
Length units	mm, µm, inch		
Angle units	degrees, radians		
Tolerance display	Upper and lower tolerance limit (per feature) Upper and lower warning limit (per feature)		
Compatibility	USB, Integrated wireless, Millimar N 1700		
Measuring combination	Predefined formula templates for standard features Links entered via comprehensive formula editor		
Features	128		
Feature types	Length, Angle, dimensionless		
Dynamic functions	MAX, MIN, MAX-MIN, MAX+MIN		
Classification	max. 20 classes		
Measuring range	mm	Dependent on measuring instrument	
Number of connectable wireless receivers for i-stick	1		
Number of connectable measuring instruments with integrated wireless	8		
Number of connectable measuring instruments with USB interface	64		
Data export	qs-Stat, Excel		
Languages:	German, English, Chinese, French, Russian, Czech		
System requirements:	MS Windows 10, MS Windows 8, MS Windows 7, 2 free USB 2.0 interfaces		

Millimar Cockpit. Measuring software

Accessories

Order no.	Product name	Product type
5331130	USB connecting module	N 1701 USB
5331120	Module for inductive probes	N 1702 M
5331133	Power supply module	N 1701 PS
5331134	I/O module	N 1704 I/O
4102220	Receiver incl. Software MarCom Std.	i-Stick
4102357	16 EXu Data Connection Cable USB (2 m) incl. Software MarCom Std.	16 EXu
4346023	2000 usb Data connection cable USB (2 m) incl. Software MarCom Std.	2000 usb
4305121	800 EWu Data Connection Cable USB (2 m) incl. Software MarCom Std.	800 EWu
4102331	Millimar - USB Adapter Cable RS232-USB (1 m) incl. Software MarCom Std.	Millimar - USB
4102330	Opto usb Adapter Cable RS232-USB (1 m) incl. Software MarCom Std.	Opto usb
4102333	817 usb Adapter Cable RS232-USB (1 m) incl. Software MarCom Std.	817 usb



N 1702 M



N 1701 PS



N 1701 USB



N 1704 I/O



i-Stick

Millimar N 1702 M. Module for inductive probes

- Flexibel combination of RS485-Bus-Modules
- Capable modules for the evaluation of measurements sensors
- Synchronous data enquiry of multiple connected sensors
- Ability to connect the N 1700 modules to the smart & universally applicable Millimar Cockpit Software
- Connection of all types of measuring sensors within the same compatibility
- Modular and customizable selection of product combinations for solving each customer specific measuring tasks
- Theoretical Bus data rate of max. 4189 values per second (depending on the number of connected channels)
- **Scope of delivery:** Instruction manual



Application:

Smart and flexible combination of modules and software for solving each customer specific measuring task.

Technical Data

Order no.		5331120
Product type		N 1702 M
Storage temperature MAX	°C	60
Storage temperature MIN	°C	-10
Resolution	µm	0,1
Measuring range, inductive probe	µm	± 2000, ± 5000
Probe inputs		2
Compatibility		Mahr, Mahr 1340, Mahr-Half bridge, Mahr-LVDT, Mahr-VLDT
Data transmission rate:	Values per second	4189
Error limit		0,3 % (min. 0,2 µm)
Data interface:		RS485
Current consumption	mA	110
Working temperature MIN	°C	10
Working temperature MAX	°C	35
Operating temperature Min	°C	0
Operating temperature Max	°C	40

Millimar N 1702 M. Module for inductive probes

Accessories

Order no.	Product name	Product type
5313010	Inductive Probe, ± 1 mm	1301
5313030	Inductive Probe, ± 1 mm	1303
5313049	Inductive Probe, ± 1 mm	1304 K
5313180	Inductive Probe, $-0,3 \dots 1$ mm	1318
5313400	Inductive Probe, ± 2 mm	1340
4400180	Inductive Probe, ± 2 mm	P1300 MA
4400182	Inductive Probe, ± 2 mm	P1300 MA without cable
4400181	Inductive Probe, ± 2 mm	P1300 MB
4400183	Inductive Probe, ± 2 mm	P1300 MB without cable
5323040	Inductive Probe, $\pm 0,5$ mm	P2001 M
5323010	Inductive Probe, ± 2 mm	P2004 M
5323020	Inductive Probe, ± 2 mm	P2004 MA
5323030	Inductive Probe, ± 2 mm	P2004 MB
5324010	Inductive Probe, ± 5 mm	P2010 M
5324020	Inductive Probe, ± 5 mm	P2010 MA
5324030	Inductive Probe, ± 5 mm	P2010 MB
5324070	Inductive Probe, ± 2 mm	P2104 MA
5324080	Inductive Probe, ± 2 mm	P2104 MB



P2001



1340



1318



1303



1304 K



P1300 MB
without cable



P1300 MB



P2104 B



P2104 A



P2010 B



P2010 A



P2004



P2004 A



P2004 B



P2010



P1300 MA
without cable



P1300 MA

Millimar N 1701 PS. Power supply module

- Flexibel combination of RS485-Bus-Modules
- Capable modules for the evaluation of measuring sensors
- Synchronous data enquiry of multiple connected sensors
- Ability to connect the N 1700 modules to the smart & universally applicable Millimar Cockpit Software
- Connection of all types of measuring sensors within the same compatibility
- Modular and customizable selection of product combinations for solving each customer specific measuring tasks
- Theoretical Bus data rate of max. 4189 values per second (depending on the number of connected channels)
- Scope of delivery Mains adapter, Instruction manual



Application:

Smart and flexible combination of modules and software for solving each customer specific measuring task.

Technical Data

Order no.	5331133	
Product type	N 1701 PS	
Data interface:	RS485	
Energy supply:	230 V/115 V; 50/60 Hz	
Current supply	mA	2000

Millimar N 1701 USB. USB connecting module

- Flexibel combination of RS485-Bus-Modules
- Capable modules for the evaluation of measurings sensors
- Synchronous data enquiry of multiple connected sensors
- Ability to connect the N 1700 modules to the smart & universally applicable Millimar Cockpit Software
- Connection of all types of measuring sensors within the same compatibility
- Modular and customizable selection of product combinations for solving each customer specific measuring tasks
- Theoretical Bus data rate of max. 4189 values per second (depending on the number of connected channels)
- Scope of deliveryEnd module, Instruction manual, USB-cable



Application:

Smart and flexible combination of modules and software for solving each customer specific measuring task.

Technical Data

Order no.	5331130	
Product type	N 1701 USB	
Data interface:	RS485	
Current supply	mA	430

Accessories

Order no.	Product name	Product type
4102058	Foot Switch to trigger data transmission	16 ESf

Millimar N 1704 I/O module

- Flexibel combination of RS485-Bus-Modules
- Capable modules for the evaluation of measuring sensors
- Synchronous data enquiry of multiple connected sensors
- Ability to connect the N 1700 modules to the smart & universally applicable Millimar Cockpit Software
- Connection of all types of measuring sensors within the same compatibility
- Modular and customizable selection of product combinations for solving each customer specific measuring tasks
- Theoretical Bus data rate of max. 4189 values per second (depending on the number of connected channels)
- Scope of delivery Plug connectors, Instruction manual



Application:

Smart and flexible combination of modules and software for solving each customer specific measuring task.

Technical Data

Order no.	5331134	
Product type	N 1704 I/O	
Data interface:	RS485	
Control inputs	4 inputs, 10 –30 V	
Control outputs	4 Ausgänge, 10 –30 V ESD protected, short-circuit proof	
Current consumption	mA	70

Multimar 844 S. Setting device

- Simple handling via clamping element
- Accurate setting of nominal value using gage block combinations
- Instrument setting in horizontal or vertical position (using base 844 Sf)
- Rigid base made of anodized aluminum, for mobile or stationary use in the production or in the inspection room
- **Scope of delivery:** Basic unit 844 S, Instruction manual



Application:

For setting indicating instruments for internal and external dimensions i. e. Multimar 844 T and Marameter 844 N at any dimension by using gage block combinations.

Technical Data

Order no.		4503500	4503501	4503502
Product type			844 S	
Application range for inside measurement from	mm		0	
Application range for inside measurement up to	mm	400	1150	2180

Accessories

Order no.	Product name	Product type
4503510	T-shaped gage blocks (20mm) for measuring depth up to 40 mm	844 Sp
4503511	Riser blocks 30mm for extended measuring depths	844 Sph
4474080	Adjustment bridge (70 x 12 mm), for measuring range 18 –250 mm	844 Neb
4474081	Adjustment bridge (165 x 17 mm), for measuring range 18 –400 mm	844 Neb
4470095	Measuring jaw for holder 420 h	844 em
4503512	Fuß für Vertikaleinsatz, inkl. Schrauben und 2 Tischklemmen	844 Sf
4474082	Adjustment bridge (320 x 20 mm), for measuring range 18 –800 mm	844 Neb

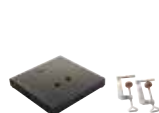

844 Sf



844 Sp



844 em



844 Neb



844 Sph

Precimar 826 PC. Gage block measuring instrument

The 826 PC gage block measuring instrument is quick, reliable and highly accurate. An open and extremely rigid L-shaped stand forms the base for the two counteracting precision measuring probes and the absolutely level measuring table.

- Rigid cast stand for temperature stability and heat resistance
- Fast adjustment of vertical slide with top probe
- Highly ergonomic, user-friendly one-handed operation to position the gage blocks under the measuring probe
- Precision adjustment via torsionally rigid parallelogram springs
- Electropneumatic lifting of measuring probes
- Precision ball-bearing guides for smooth manipulator actuation
- No influence on measurement from hand force
- Round carbide precision support pins make it easy to move the gage blocks on the measuring table
- Set value linked to the stored actual deviation of the reference gage block, avoiding the need for zero point setting

With QM-Block software:

- Flattening correction
- Correction of differing coefficients of expansion
- Mean-value generation



Technical Data

	826 PC
Application range [mm]	0.5 to 170
Direct measuring range [mm]	0,2
Repeatability [μm]	$\pm 0,01$
Mass [kg]	37

Applications

- Quick and easy, high-precision testing of European and US gage blocks up to 170 mm in length, as per ISO 3650

Accessories

- QMSOFT® / QM-Block calibration software for the calibration and data management of gage blocks and gage block sets
- The evaluation program runs under Windows 7 Ultimate.
- Excellent thermal insulation with wraparound acrylic glass screen
- 826 Va HS lifting device for fast and quiet pneumatic lifting of inductive probes via foot switch
- Temperature compensation
- Pincers, gage block suction lifter, optical flat, lay-on thermometer



For more information, please visit our website: www.mahr.com

Precimar Optimar 100 BV. Dial indicator test device

- OPTIMAR 100 with image processing is the most cost-effective test station for the partially or fully automated testing of dial indicators, dial comparators and test indicators. The retrofit kit for image processing enables you to complete your motorized dial indicator test device with the possibility of a fully automatic reading of the displayed values of the test objects (pointer or numeric display) by camera and image processing, which makes the testing process considerably easier.
- Easy to use
- Quick image processing due to USB 3.0-camera
- Compact design
- Digital digit recognition
- Steady LED lighting which does not require daylight
- No interface cable necessary
- During the automated testing process, the released capacities of the operator can be used for other working tasks.
- **Supplied with:**
- Retrofit kit for Optimar 100 dial indicator test device with image processing consisting of:
 - base unit
 - USB 3.0 camera with lens incl. cable
 - Lighting unit complete with plug-in power supply
 - Software QMSOFT/QM-DIAL Image Processing



Technical Data

	Optimar 100 BV
Measuring range	0 – 100 mm
Measuring uncertainty MPE_{E1} (L in mm) [μm]	$\leq (0,2 + L/250)$
Digital numerical increment [μm]	0,02

Applications

- calibration of dial indicators, dial test indicators and dial comparators
- The QMSOFT® software system controls the dial indicator test device Optimar 100 and processes the camera image (pointer or numeric display of the test object) and the reference measuring values of the dial indicator test device Optimar 100; it also performs all the subsequent processes related to gauge management.
- The output of the inspection results are numerical data lists and graphics showing the deviation course. Tolerance excesses are marked and identified.
- Support the inspection of this gauges according to the worldwide mostly used standards.



For more information, please visit our website: www.mahr.com

Precimar PLM 1000-E. Precision length measuring machine

The PLM-E precision length measuring machine is an Abbe-compliant comparator with horizontal base bed (highly homogeneous, rigid granite)

- Sensitive adjustment in 5 axes, and object table with a loading capacity of 35 kg
- PC-based, multiaxis machine control, including PC workstation and 828 WIN „Free measurement“ basic software
- Simple operating procedure by means of measuring force-adjusted and joystick-controlled measuring slides with progressive deflection characteristic and automatic contact detection
- Automatic detection of outside and inside measurements and computer-aided search for reversal points
- The motorized measuring slide allows for high travel speeds
- The CNC-controlled vertical and cross adjustment of the universal measuring table facilitates highly efficient measuring
- State-of-the-art machine control (MarEcon)
- Recording, processing, logging and transfer of measurement data via powerful software and menu-driven controls
- Software compensation of thermal dimensional deviations
- Very easy to set the measuring force using the software
- Aerostatic guides for all slides mounted on the machine bed ensure low measurement uncertainties
- Electronic generation of measuring force and automatic contacting
- Subjective influences largely eliminated and unintended collisions with the testpiece avoided.
- Automatic bore and inner thread measurement
- Automatic TY adjustment: What's unique is that a manual TY-adjustment is still possible
- Motorized tilting axis (TB) for alignment. Alignment is carried out via the manual control panel or using the 828 WIN software.
- A factory calibration or DAKkS/ DKD calibration is available for the Precimar PLM-E



Technical Data

	PLM 1000-E
Direct measuring range [mm]	200
Measuring range for outer measurement [mm]	0 to 1000
Measuring range for inner measurement [mm]	0,5 to 845
Measuring uncertainty MPE_{E1} (L in mm) [μm]	$\leq (0,085 + L/1500)$
Position deviation / error limit (L in mm) [μm] *	$\leq (0.07 + L/2000)$
Repeatability [μm]	≤ 0.05
Measuring forces [N]	0 to 13,9
Device length [mm]	2110
Mass [kg]	535

* Proof can be carried out at the Göttingen site if required

Applications

Calibration of

- Plain plug gages and gage rings
- Setting gage rings
- Snap gages
- Spherical gage blocks, internal micrometers
- Gage blocks
- Thread gages
- Taper thread gages
- Gear gages
- Dial indicators
- Dial comparators
- 2-point bore gages
- Outside micrometers
- 2-point inside micrometers
- Precision length measurement
- Measurement of thin-walled and deformed workpieces

Accessories

Large number of accessory kits and modular components for solving a wide variety of measuring tasks, including the measurement of:

- Thread gages
- Conical thread gages
- Gears
- Thread pitches



For more information, please visit our website: www.mahr.com

MarSurf PS 10 C2. Mobile Roughness Measuring Instrument

„sMAHRtSurf“ - Simple, smart and mobile



- Compact roughness measuring instrument for mobile use
- Simple and intuitive to use: As easy to use as a smart phone
- Large, illuminated 4.3" TFT touch display
- Adjustable display
- Start button also serves as the Home button for direct access to the start screen
- Data backup as TXT, X3P or PDF file
- Creation of completed PDF measuring records in the measuring device
- Customer-specific comments for the PDF measuring record are entered directly into the MarSurf PS 10
- Mains-independent operation: Over 1200 measurements without having to recharge the instrument
- An all-in-one solution. Small and lightweight (approx. 500 g)
- Instrument flexibility: Removable drive unit
- All the measuring positions you need: horizontal, vertical, upside down
- 31 surface parameters offer the same range of functions as a laboratory instrument.
- Error-free operation thanks to an integrated, removable roughness standard
- Quick access to your frequently used functions via the Favorites list in the display
- Very short activation time: results available within seconds
- Automatic cutoff selection, so even non-specialists can be sure of getting the correct measuring results
- **Scope of delivery**
- MarSurf PS 10 unit
- Drive unit RD18C2 (detachable)
- Handheld Vee block
- 1 standard probe conforming to standards
- Built-in rechargeable battery
- Roughness standard integrated into housing (detachable), including Mahr calibration certificate
- Probe protection
- Charger / 3 adapters
- Operating instructions
- Carry case with shoulder strap
- USB cable
- Extension cable for drive unit
- Height adjustment (integrated)



Application:

- For transverse scanning i.e. on crank or camshafts



Technical Data

Order no.	6910235	
Product type	PS 10 C2	
Parameters	Ra, Rq, Rz (Ry (JIS) is equivalent to Rz), Rz (JIS), Rmax, Rp, RpA (ASME), Rpm (ASME), Rpk, Rk, Rvk, Mr1, Mr2, A1, A2, Vo, Rt, R _{Pc} , R _{mr} (tp (JIS, ASME) is equivalent to R _{mr}), R _{Sm} , R _{Sk} , RS, CR, CF, CL, R, Ar, Rx	
Stylus	2 µm	
Calibration function	dynamic; Ra, Rz, R _{Sm}	
Storage capacity	min. 3900 profiles, min. 500,000 results, min. 1500 PDF records, expandable with microSD card up to 32 GB	
Languages:	German, English, French, Italian, Spanish, Portugese, Dutch, Swedish, Russian, Polish, Czech, Japanese, Chinese, Korean, Hungarian, Turkish, Romanian	
Other	Lock/password protected, date/time	
Data interface:	USB, MarConnect (RS232), microSD slot for SD / SDHC cards up to 32 GB	
System of protection	IP 40	
Rechargeable batteries	Lithium-ion battery, min. 1200 measurements	
Wide range power supply	100 to 264 V	
H x W x D	mm	160 mm x 77 mm x 50 mm
Weight	kg	0,49
Measuring principle	Stylus method	
Probe	inductive skidded probe	
Measuring range	mm	0.350
Profile resolution	8 nm	
Filter according to ISO/JIS	Gaussian filter as per ISO 16610-21 (formerly ISO 11562), special filter as per DIN EN ISO 13565-1, Lambda s filter as per DIN EN ISO 3274 (can be switched off)	
Cutoff l_c according to ISO/JIS	0,25 mm, 0,8 mm, 2,5 mm, automatic filter detection	
Number n of sampling length according to ISO/JIS	selectable: 1 to 16	
Short stroke under ISO/JIS	selectable	
Traversing length l_t according ISO/JIS	1.5 mm, 4.8 mm, N x l _c , variable, automatical	
Traversing length according ISO 12085 (MOTIF)	1 mm, 2 mm, 4 mm	
Evaluation lenth l_n according to ISO/JIS	1.25 mm, 4.0 mm	
Measuring force	N	0.00075

MarSurf PS 10 C2. Mobile Roughness Measuring Instrument

Accessories

Order no.	Product description	Product type
6850738	Collet chucks for RD 18 C2 / PFM-2 for \varnothing 5–80 mm	RD 18 C2
6111520	Standard probe 2 μ m	PHT 6–350
6111526	Standard probe 5 μ m	PHT 6–350/ 5 μ m
6111527	Standard probe 10 μ m	PHT 6–350/ 10 μ m
6111521	Probe for bores with a dia. larger than 3 mm	PHT 3–350
6111524	Probe for grooves	PHT 11–100
6820420	Roughness standard with Mahr calibration certificate, profile depth 10 μ m	PRN 10
6820602	Geometric Standard with sinusoidal groove profile, Profiltiefe 1,5 μ m	PGN 1
6820601	Geometric Standard with sinusoidal groove profile, Profiltiefe 3 μ m	PGN 3
6820605	Geometric Standard with sinusoidal groove profile, Profiltiefe 10 μ m	PGN 10
9027715	Mahr-calibration certificate for PGN Standard	PGN
6980102	DKD (German Calibration Service) calibration certificate for PGN Standard	PGN
4102357	Data Connection Cable USB	16 EXu
4102410	Data Connection Cable RS232C	16 EXr
4102231	Transmitter	16 EWe
4102230	Receiver	e-Stick
6910209	Mount MarSurf PS 10 on measuring stand ST	ST-a3
6710803	Measuring stand 300 mm with cast iron base	ST-D
6710806	Measuring stand 300 mm with granite plate	ST-F
6710807	Measuring stand 300 mm with granite plate and T-slot	ST-G
2247086	Adjustable mounting bracket to connect to 814 SR	814 Sh
4426100	Height Measuring and Scribing Instrument	814 SR
4426101	Height Measuring and Scribing Instrument	814 SR
6910435	RD 18 C / PS 10 upright holder for cylindrical drive unit, \varnothing 8 mm	ST-a2
4413000	Indicator Stand with Base	815 GN
4413001	Indicator Stand with Base	815 GN
4413005	Indicator Stand with Base	815 GN
4416000	Indicator Stand with Magnetic Base	815 MA
6299054	Evaluation Software	SW XR 20



e-Stick



16 EWE



814 SR



814 Sh



ST-G

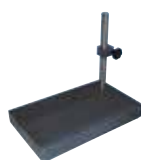

ST-F



ST-D

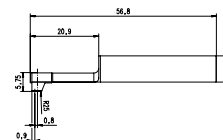

PHT 6–350

MarGear GMX 400 W. Universal gear measuring center

Precision, fully automatic testing of gears and gear cutting tools up to an outer diameter of 400 mm.

Combining gear measuring tasks with various form & position features has never been easier.

With over 6000 units sold, the MarWin environment is a clear and simple way of creating complete programs in Teach In mode.

This improves programming efficiency and reduces the possibility of incorrect use.

Proven GMX realtime machine error correction is also used for positioning movements with the new MarEcon control unit, guaranteeing maximum speed and precision throughout the entire measuring and movement sequence.



Gear and form measurements carried out on a single measuring instrument.

High-precision 3D scanning sensor combined with directly driven C-axis for accuracy and efficiency

Control unit
5-axis control unit

With the long tailstock option transmission shafts up to 700 mm can be clamped.

Inspection features

- Straight and helical toothed cylindrical gears
- GDE interface for inner and outer gears
- Data export to QS-STAT
- Form and position measurements
- 3D geometries such as distances, cone angles, etc.

Accuracy

MarGear GMX 400 W
Gear measuring instrument, accuracy class 1, for gear measurements in accordance with VDI/VDE 2612/2613 Group 1 at 20°C ± 2 K (Rotational axis in Formtester accuracy)

Technical Data

GMX 400 W	
Measuring path (mm), X-axis	200
Measuring path (mm), Y-axis	200
Measuring path (mm), Z-axis	320
Diameter max.* [mm]	400
Length	1560
Width	600
Height	1787
Mass [kg]	700
Max. workpiece weight [kg]	60 (80 on request)
Accuracy	Accuracy class I for gear measurements in accordance with VDI/VDE 2612/2613 Group 1 at 20°C ± 2°C
Axial run-out deviation (µm+µm/mm measuring radius)	0.11 µm + 0.0008 µm/mm
Radial run-out deviation (µm in table height)	≤ 0.11 µm

* max. diameter of cylindrical gears

Applications

- Basic measuring station with AdvancedForm software
- Suitable for use as a gear measuring station with QE Cylindrical Gear

Accessories

- Active vibration damping system
- Revolving counter-tip
- Data matrix scanner
- Chuck 70 mm
- Chuck 200 mm
- Drive pin set
- Tailstock 450 mm or 700 mm



For more information, please visit our website: www.mahr.com

MarGear GMX 400 ZLW. Universal gear measuring center

Precision, fully automatic testing of gears and gear cutting tools up to an outer diameter of 400 mm.

Combining gear measuring tasks with various form & position features has never been easier.

With over 6000 units sold, the MarWin environment is a clear and simple way of creating complete programs in Teach In mode.

This improves programming efficiency and reduces the possibility of incorrect use.

Proven GMX realtime machine error correction is also used for positioning movements with the new MarEcon control unit, guaranteeing maximum speed and precision throughout the entire measuring and movement sequence.

Gear and form measurements carried out on a single measuring instrument.

High-precision 3D scanning sensor combined with directly driven C-axis for accuracy and efficiency

Control unit
5-axis control unit

With the long tailstock option transmission shafts up to 700 mm can be clamped.

Inspection features

- Straight and helical toothed cylindrical gears
- GDE interface for inner and outer gears
- Data export to QS-STAT
- Form and position measurements
- 3D geometries such as distances, cone angles, etc.

Accuracy

MarGear GMX 400 ZLW
Gear measuring instrument, accuracy class 1, for gear measurements in accordance with VDI/VDE 2612/2613 Group 1 at 20°C ± 2 K (Rotational axis in Formtester accuracy)



Technical Data

GMX 400 ZLW	
Measuring path (mm), X-axis	200
Measuring path (mm), Y-axis	200
Measuring path (mm), Z-axis	650
Diameter max.* [mm]	400
Length	1560
Width	600
Height	2147
Mass [kg]	750
Max. workpiece weight [kg]	60 (80 on request)
Accuracy	Accuracy class I for gear measurements in accordance with VDI/VDE 2612/2613 Group 1 at 20°C ± 2°C
Axial run-out deviation (µm+µm/mm measuring radius)	0.11 µm + 0.0008 µm/mm
Radial run-out deviation (µm in table height)	≤ 0.11 µm

* max. diameter of cylindrical gears

Applications

- Basic measuring station with AdvancedForm software
- Suitable for use as a gear measuring station with QE Cylindrical Gear

Accessories

- Active vibration damping system
- Revolving counter-tip
- Data matrix scanner
- Chuck 70 mm
- Chuck 200 mm
- Drive pin set



For more information, please visit our website: www.mahr.com

MarGear. MarWin Software solutions

- In addition to simple controls, the new software offers users a variety of interfaces to simplify automation of the measuring procedure. When you import gear data, in GDE format for example, the software creates a 3D model of the gear for visual inspection and checks the tooth geometry for plausibility. This further reduces the possibility of operator errors.



Software highlights

- The intuitive „QE Cylindrical Gear“ user interface provides a number of interfaces for importing and exporting data.
- Using the QEP interface (Quick&Easy profile) you can archive profile and results data relating to a gear measurement in MarWin format and then reload it subsequently for evaluation.
- The new „QE Cylindrical Gear“ module is the latest measuring module to be added to the MarWin platform. Q&E modules from the MarWin system can be linked together quickly and easily to create a complete program for a transmission shaft, for example.

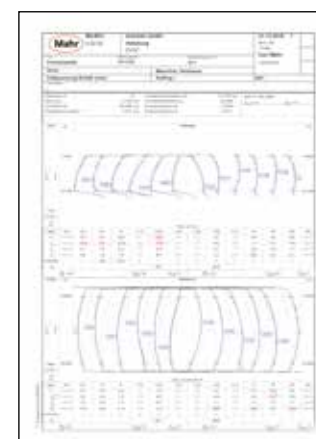
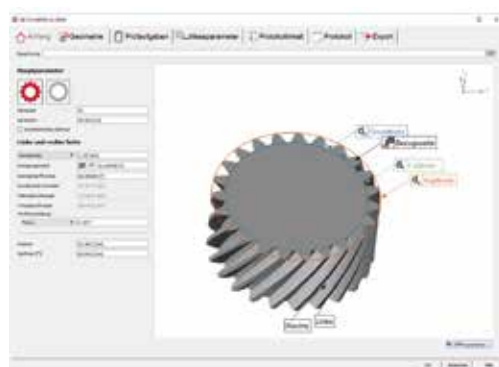
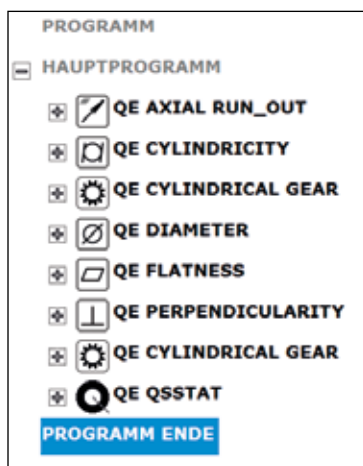

For more information, please visit our website: www.mahr.com

MarShaft SCOPE 250 plus

- The role of dimensional metrology is expanding at a dramatic rate, in parallel with innovations in manufacturing processes. Given the ever more stringent accuracy requirements and falling cycle times in production (turning, milling, grinding, etc.), rapid measurement directly at the manufacturing machine is absolutely essential. Measurement at the point of origin of the product, with rapid feedback to the manufacturing process to avoid waste. Mahr's flexible MarShaft SCOPE 250 plus shaft measuring machine offers the right measuring solution for the fast, precise and fully automatic measurement of rotationally symmetrical workpieces in production.

- The MarShaft SCOPE 250 plus has a high precision roundness measuring axis (C) and a vertical measuring axis (Z) with a measuring range of 250 mm. At its heart is the state-of-the-art, high-resolution CMOS matrix camera (live image) with an image field of 1088 x 2048 mm. The extremely high image acquisition rate of over 120 images per second keeps measuring times to a minimum. Zoom functions allow the smallest details to be measured, which with conventional measuring methods are difficult if not impossible to test.

Performance features at a glance:

- New, high-resolution CMOS matrix camera with a 40 mm live image field allows fast scanning with over 120 images per second
- High accuracy for diameter and length measurement
- Extremely fast measuring times thanks to high measuring speeds of up to 200 mm/s
- By using Mahr's MarWin software platform, you can benefit from our decades of experience in length, shape, position and contour measurement
- Affordable entry-level price into the small optical shaft measuring machine segment



Technical Data

MarShaft SCOPE 250 plus	
Measuring range length (Z) (mm)	250
Measuring range diameter (X) (mm)	40
Length/diameter resolution (mm)	0.01...0.0001
Angle resolution (°)	0.01...0.0001
Length error limit (Z) (µm)	≤ (3.0+I/125) L in mm
Diameter error limit (X) (µm)	≤ (1.5+I/40) L in mm
Lens	Telecentric precision optics High-resolution CMOS camera

Applications

The main measurable features

- Length
- Diameter
- Form and position tolerances
- Offsets
- Recess width
- Bevel width
- Intersection points
- Position of intersection points
- Angles of rotation
- Radii
- Position of radii
- Taper lengths
- Angles
- Pitches
- Widths across flats
- Outer threads



For more information, please visit our website: www.mahr.com

MarShaft. Scope 600 plus 3D

- Mahr is pleased to provide a new measurement method for the special camshaft application using the new MarShaft SCOPE 600 plus 3D: A combination of optical and touch sensors allow for a first ever functionally complete 3D Inspection of the workpiece. Due to this market need Mahr further developed our highly anticipated and received MarShaft SCOPE 750 plus System. The advanced System now utilizes a new 2D Touch Probe, a motorized tailstock and a calibration for the linear axes. A Matrix camera optically measures characteristics such as diameters, lengths, radii, geometries, location characteristics, cam angle or cam lift in seconds. The additional 2D Sensor detects features that are not optically measurable: concave cam shapes, axial run out on large shoulders, reference elements in the axial direction such as blind holes. For this system, the tactile and optical systems are aligned/adjusted to exist within one measuring coordinate system. This unit operates in conjunction with the MarWin software platform, thus providing full 3D functionality.

Features:

- Complete measuring of camshafts, including cam angle and all cam profiles
- Measurement of contours
- No use of radial drivers
- Direct measurement of reference (2 flat,, blind borehole or keyway)
- Measurement of keyway grooves
- Measurement of blind boreholes
- 100% 3D function with the new 2D probesystem 1320-2
- Additional Y- measuring axis
- Special calibration of the linear axis (Z-X-Y)
- MarShaf Professional Software
- Manual panel

Options:

- Barcode-Scanner
- Signal light (red, yellow, green)
- Coated tip (no driver required)
- Vibration isolation system
- Temperature compensation
- Thread Measurement
- Turbocharger shaft measurement



Technical Data

MarShaft SCOPE 600 plus 3D	
Measuring range length (Z) (mm)	600
Measuring range diameter (X) (mm)	120
Workpiece weight (max.) in kg	15
Length/diameter resolution (mm)	0.01 to 0.0001
Angle resolution (°)	0.01 to 0.0001
Length error limit (Z) (µm)	(2,0 + L/125) L in mm (at 20 °C ± 1 °C on reference standard)
Diameter error limit (X) (µm)	(1,0 + L/125) L in mm (at 20 °C ± 1 °C on reference standard)
Drive	Servo motors
Lens	Telecentric precision lens High-resolution CCD array

Applications

Complete measurement of camshafts

Typical workpieces

- Camshaft
- Eccentric shafts
- Shafts with keyways or blind boreholes



For more information, please visit our website: www.mahr.com

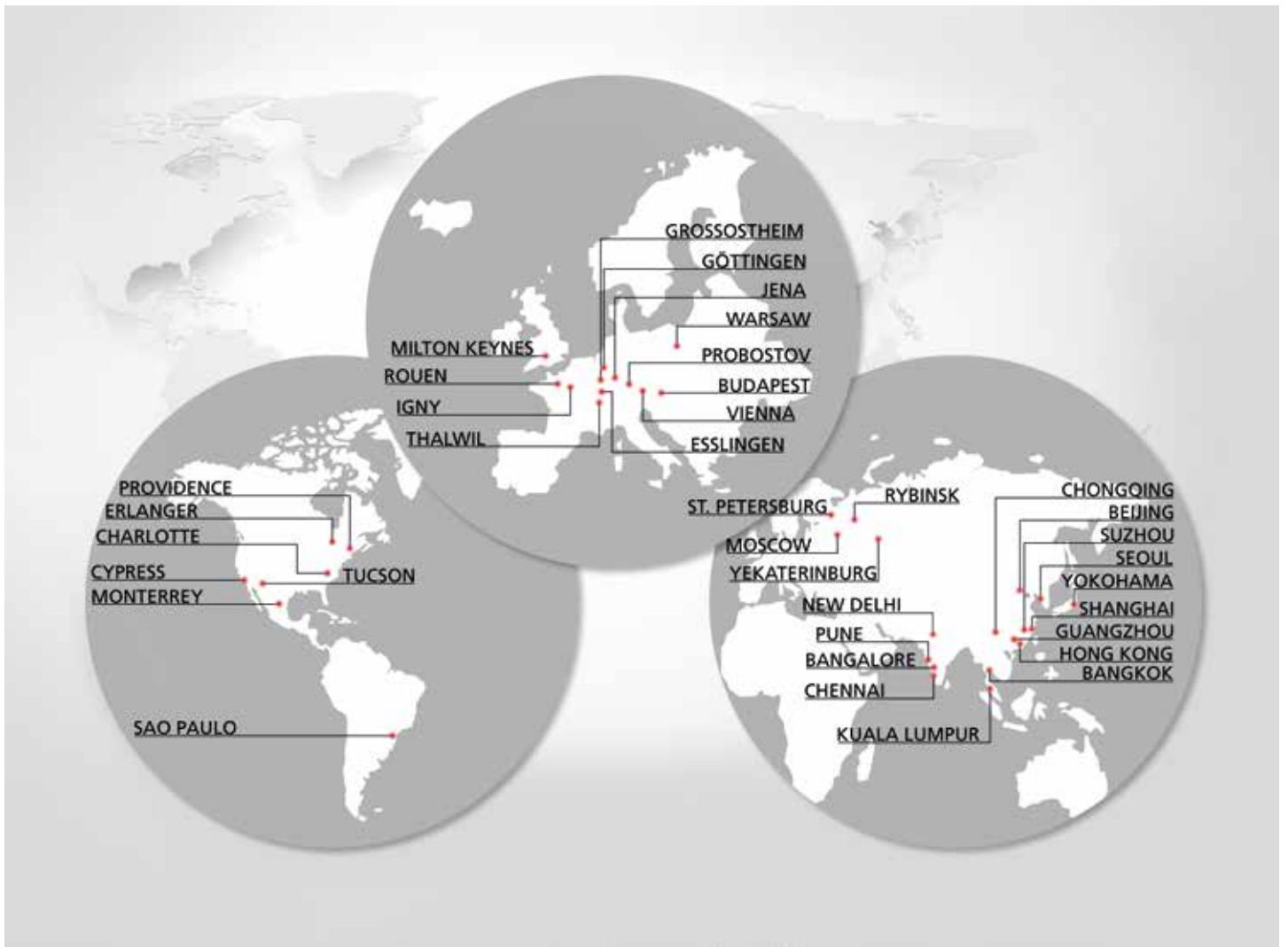

Partner for manufacturing companies worldwide.

Close to our customers.

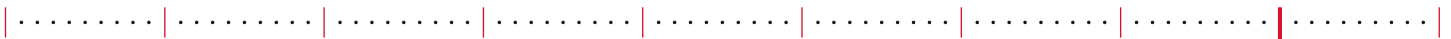
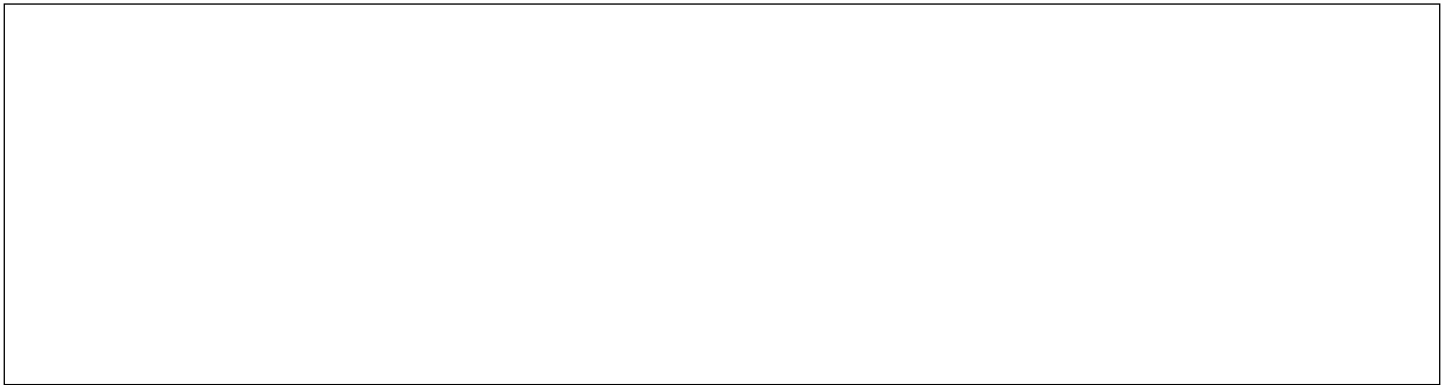

Mahr GmbH

Carl-Mahr-Straße 1, 37073 Göttingen, Germany
Reutlinger Str. 48, 73728 Esslingen, Germany

Telefon +49 551 7073-800, Fax +49 551 7073-888

info@mahr.de, www.mahr.com



© Mahr GmbH

We reserve the right to make changes to our products, especially due to technical improvements and further developments. All illustrations and technical data are therefore without guarantee. All list prices are the recommended retail prices.

3723186 | 04.2017

- 0 +



E X A C T L Y